

Features

- Low Supply Current ~ 45uA (per circuit)
- Low Shutdown Current ~0.1uA (Typ.)
- Output Current ~150mA
- High Power Supply Rejection Ratio ~75db@1KHz
- 2~5.5V Operation
- ±1.0% Initial Voltage Accuracy
- Low Temperature Drift Coefficient ~50ppm/°C
- Line Regulation ~0.02%/V(Typ.)
- Low ESR Capacitor ~1uF ceramic capacitor
- WDFN6-1.6x1.6、TDFN6-1.8x2 and SOT-23-6 package
- Green Product (RoHS, Lead-Free, Halogen-Free Compliant)

Applications

- Portable communication equipment
- Notebook Computer
- Battery Powered Systems

Typical Application

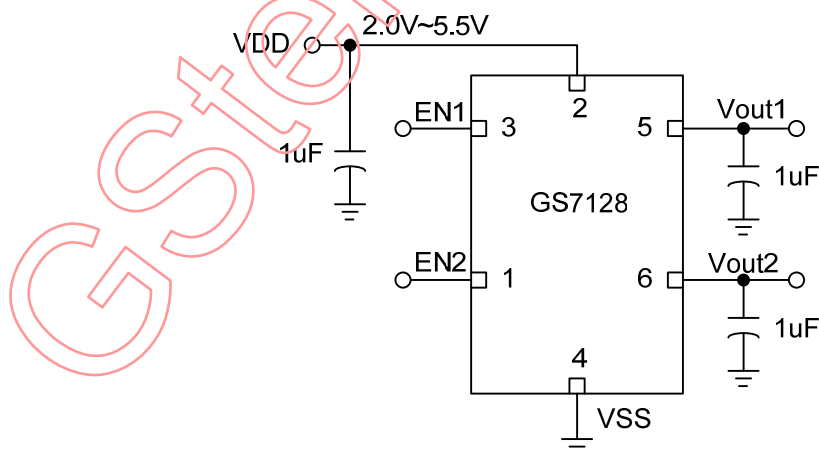

Figure 1 Typical Application of GS7128

General Description

The GS7128 is a CMOS linear regulator. It is featuring ultra-high power supply rejection ratio, low output voltage noise, low dropout voltage, low quiescent current and fast transient response. It guarantees delivery of 150mA output current, and supports preset 1.2V, 1.3V, 1.5V, 1.8V, 2.5V, 2.8V, 3.0V, 3.3V output voltage versions.

Based on its low quiescent current consumption and its less than 1uA shutdown mode, the GS7128 is ideal for battery- powered applications. The high power supply rejection ratio of the GS7128 holds well for low input voltages typically encountered in battery- operated systems. The regulator is stable with small ceramic capacitive loads (1μF typical).

This document is GStek's confidential information. Anyone having confidential obligation to GStek shall keep this document confidential. Any unauthorized disclosure or use beyond authorized purpose will be considered as violation of confidentiality and criminal and civil liability will be asserted.